

SMARTCRYSTAL™ model VPSP-08000
DIAMOND
USER MANUAL

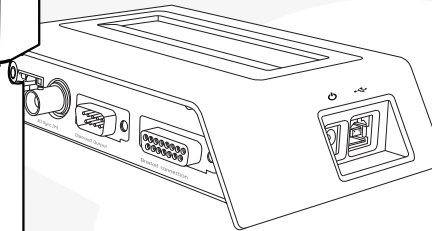

TABLE OF CONTENTS

Content	Page	Content	Page
1. INTRODUCTION		6. SOFTWARE INTERFACE	
1.1 GENERAL POINTS	2.	6.1 INTRODUCTION	22.
1.2 CONTENTS OF THIS MANUAL	2.	6.2 SCD SOFTWARE VERSION	22.
1.3 SPECIFICATION OF THE PROJECTOR	2.	6.3 FUNCTIONING MODES, SETTINGS, OTHER FUNCTIONS	22.
1.4 SPECIFICATIONS OF THE BRACKET	2.		
1.5 VOLFONI PASSIVE GLASSES	2.	7. TROUBLESHOOTING	23.
2. SMARTCRYSTAL™ DIAMOND PRESENTATION		8. IMPORTANT SAFETY RECOMMENDATIONS	24.
2.1 THE SMARTCRYSTAL™ DIAMOND BOX	4-5.	9. WARRANTY	24.
2.1.1 General presentation		10. FURTHER INFORMATION	24.
2.1.2 Detailed presentation		11. REGULATORY STANDARDS	24.
2.2 THE SMARTCRYSTAL™ DIAMOND CONTROLLER	6-7.		
2.2.1 General presentation			
2.2.2 Detailed presentation			
2.3 THE SMARTCRYSTAL™ DIAMOND BRACKET	7.		
3. REQUIREMENTS AND IMPORTANT RECOMMENDATIONS TO INSTALL THE SMARTCRYSTAL™ DIAMOND			
3.1 ROOM CONFIGURATION	8.		
3.2 FILM THEATRE CONFIGURATION	8.		
4. SMARTCRYSTAL™ DIAMOND ASSEMBLY			
4.1 LOADING THE ADJUSTMENT PATTERN	9.		
4.2 BRACKET INSTALLATION	9.		
4.3 INSTALLATION OF THE SMARTCRYSTAL™ DIAMOND BOX ON THE BRACKET	9-11.		
4.3.1 Assembly of the SmartCrystal™ Diamond box on the bracket			
4.3.2 Adjustment of the SmartCrystal™ Diamond Box position			
4.3.3 2-D/3-D position stops			
4.4 IMAGE ADJUSTMENT	12-18.		
4.4.1 FITTING THE UPPER HALF IMAGE			
4.4.2 FITTING THE LOWER HALF IMAGE			
4.5 SMARTCRYSTAL™ DIAMOND CONTROLLER PLUG-IN	19.		
4.5.1 CASE OF AN INSTALLATION WITH A MANUAL BRACKET			
4.5.2 CASE OF AN INSTALLATION WITH A MOTORIZED BRACKET			
4.6 3-D FUNCTIONING TEST	20.		
5. ADDITIONAL ANTI-REFLECTION FILTER			
5.1 CONTEXT	21.		
5.2 FILTER ASSEMBLY	21.		

1.Introduction

1.1 General points

The SmartCrystal™ Diamond is the latest passive 3-D innovation offered by Volfoni.

The SmartCrystal™ Diamond is directly put in front of a 3-D projector lens. Combined with an appropriate screen (silvered screen), it enables the audience wearing passive 3-D glasses to see in three dimensions.

The SmartCrystal™ Diamond technology offers a unique visual experience:

- High light performance
- Easy and quick installation: light and small-sized, it enables you to adapt to the variety and complexity of several configurations such as 'boothless', and can be easily installed or uninstalled.
- 2-D/3-D configuration: The system is ideally designed to be assembled with a support which enables you to move it manually/automatically according to the 2-D or 3-D projection mode.
- Compatibility: The SmartCrystal™ Diamond works for DLP digital projectors offered by Christie, Barco, NEC. For every other model, we invite you to contact Volfoni directly.

1.2 Contents of this manual

This manual is aimed at providing the SmartCrystal™ Diamond installation instructions and maintenance operations.

This manual has to be used while following the working and security rules of the projector, which are among other information mentioned in the projector user manual.

- Presentation of the SmartCrystal™ Diamond components
- Installation and adjustment of the SmartCrystal™ Diamond Box
- Installation and connection of the SmartCrystal™ Diamond Controller
- Transition from 2-D to 3-D mode and conversely
- Maintenance

This manual is meant for fitters who are entitled to install the SmartCrystal™ Diamond. The use of this manual implies that the cinema's equipment respects all the 3-D screening necessary conditions such as the lamp type, the silvered screen or the glasses type.

This manual is exclusively meant for professionals who are authorized to operate on screening systems in cinema projection rooms. Skilled technicians only, who are aware of potential dangers associated with high voltage, ultraviolet exposure and high temperatures generated by lamps and their power circuit, are authorized to install/deinstall the SmartCrystal™ Diamond and to service it.

1.3 Specification of the projector

The SmartCrystal™ Diamond is used with digital cinema projectors. It has been designed to work with the various digital cinema projectors developed by the main manufacturers using the Texas Instrument DLP® technology.

This manual is based on the assumption that all of the specifications for the installation of the projector have been respected and that the projector is ready for use. This manual has to be used while respecting the instructions for the installation of your system, among them the projector's user guide.

1.4 Specification of the bracket

The SmartCrystal™ Diamond is assembled on a specific bracket.

This manual is based on the assumption that all the specifications for the installation of the bracket have been respected and that the bracket is ready for use. This manual has to be used while respecting the installation instructions of your system, among them the bracket user guide.

1.5 Volfoni passive glasses

With the SmartCrystal™ Diamond, the audience is required to wear passive glasses with circular polarization to watch 3-D contents.

Volfoni offers passive glasses with circular polarization which are optimized for a better quality 3-D visual experience.

These glasses are disposable or washable under the conditions recommended by Volfoni.

The polarizer filters of the glasses need to be compatible with the polarization generated by the SmartCrystal™ Diamond.

WARNING
THE CINEMA PASSIVE GLASSES MUST NOT BE USED AS SUNGLASSES.
POLARIZER FILTERS CANNOT PROTECT FROM ULTRAVIOLETS.

2. SmartCrystal™ Diamond presentation

Each SmartCrystal™ Diamond is made up by the following components:

- SmartCrystal™ Diamond Box (opto-mechanical unit)
- SmartCrystal™ Diamond Controller (electronic unit)
- One set of 3-D bus cables (GPIO37-BNC, SubD15-BNC, BNC-BNC),
- Connection cable between SCD Box and SCD Controller (SubD9 M/F),
- Feeder cable (220/110V) with US, EU, UK, AUS plugs.
- Software maintenance cable (USB A-USB B)
- Volfoni passive glasses (2 pairs)
- Optional anti-reflection filter for room window
- USB key with aligning pattern and technical data
- Tools, holding screws
- Cleaning wipe
- Quick Start

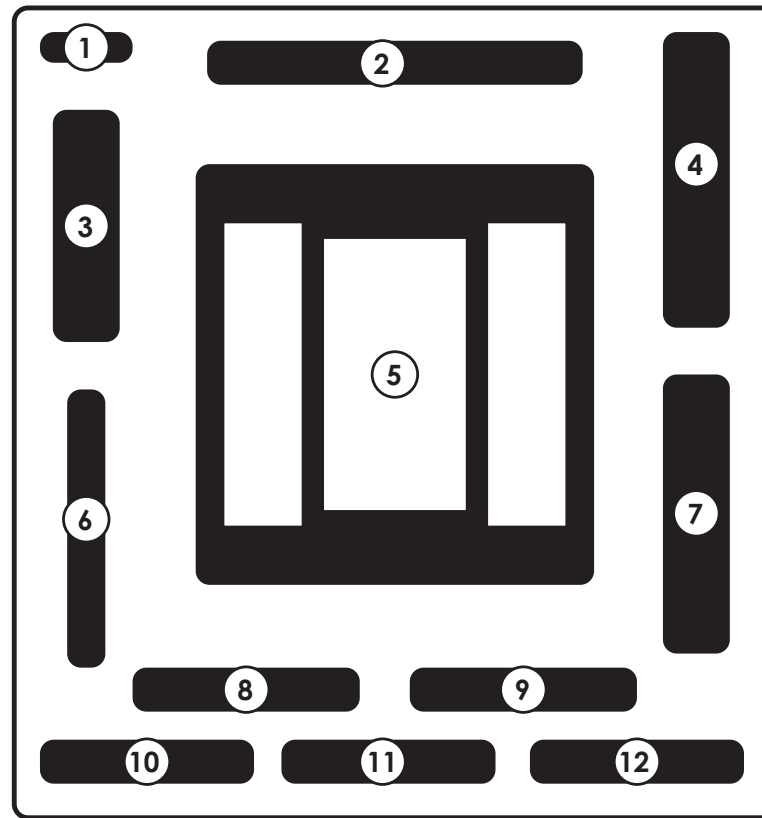

Fig 1

- ① USB Key + Wipes (x2)
Cordon réseau
- ② RJ45 Cable
Used for network control
- ③ USB-A / USB-B Maintenance cable
Cable is dedicated for maintenance with Volfoni Software
- ④ SmartCRYSTAL™ Diamond Controller
- ⑤ SmartCRYSTAL™ Diamond System
- ⑥ Polarization Filter
Optionnal filter. Only use in case of anormal reflections
- ⑦ SUB-D 9pts
Dedicated to connect SCD Controller and SCD System
- ⑧ GPIO-15 pins & BNC / BNC Cables
3D Synchronization cable
- ⑨ Passive glasses VPPG-03000 (x2)
- ⑩ GPIO-37 pins Cable
3D Synchronization cable
- ⑪ International plugs
(EU, US, AUS, China, UK)
- ⑫ Power supply

Each SmartCrystal™ Diamond will be delivered with a bracket which must be installed while respecting the instructions of its user guide.

2.1 The SmartCrystal™ Diamond Box

2.1.1 General introduction

The SmartCrystal™ Diamond Box is the opto-mechanical unit.

The SmartCrystal™ Diamond technology splits up the incident light flux into three separate fluxes:

- The central flux (full image)
- The upper flux (upper half image)
- The lower flux (lower half image)

The system adjustment consists in perfectly recombining these three fluxes on the screen into a single image (see below).

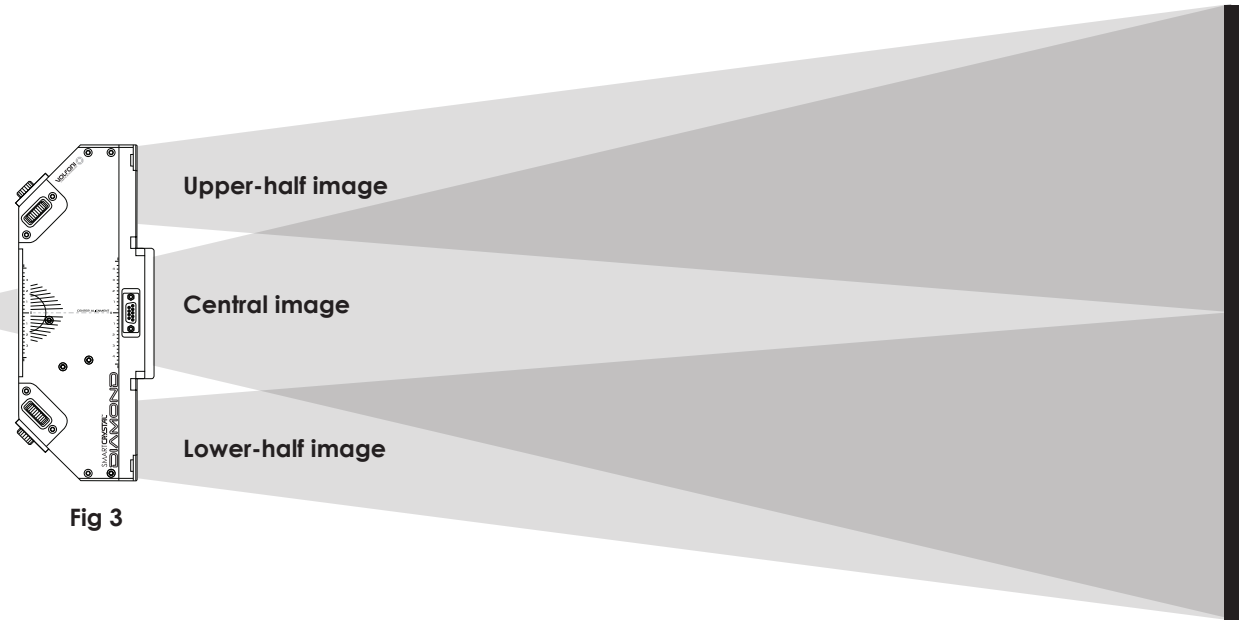
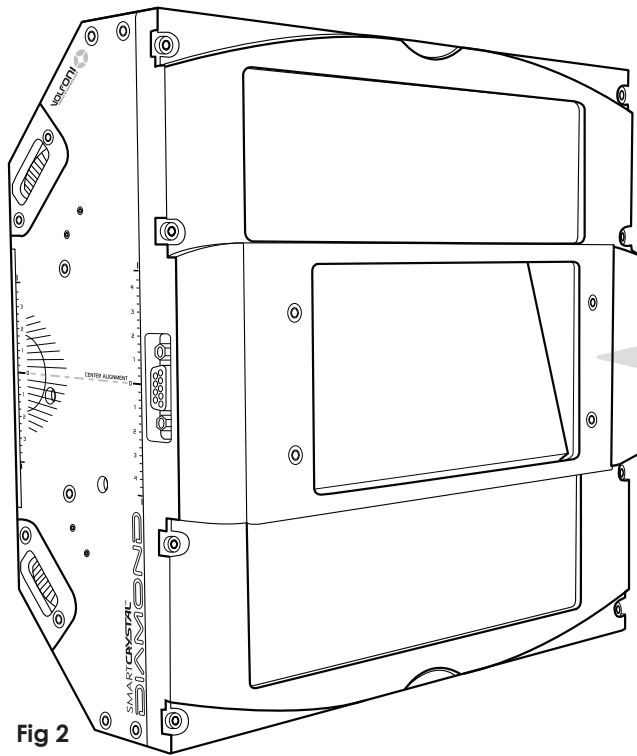

2.1.2 Detailed presentation

The SmartCrystal Diamond Box is compact and light:

- Dimensions: W 28 cm X H 26 cm X D 10 cm
- Weight: about 6kg.

On one side, the 'screen' side of the SmartCrystal™ Diamond Box is made up of the three outflow windows.

On the other side, the 'projector' side is made up of the entry window of the SmartCrystal™ Diamond Box, so as of two wheels to adjust the system (see below).

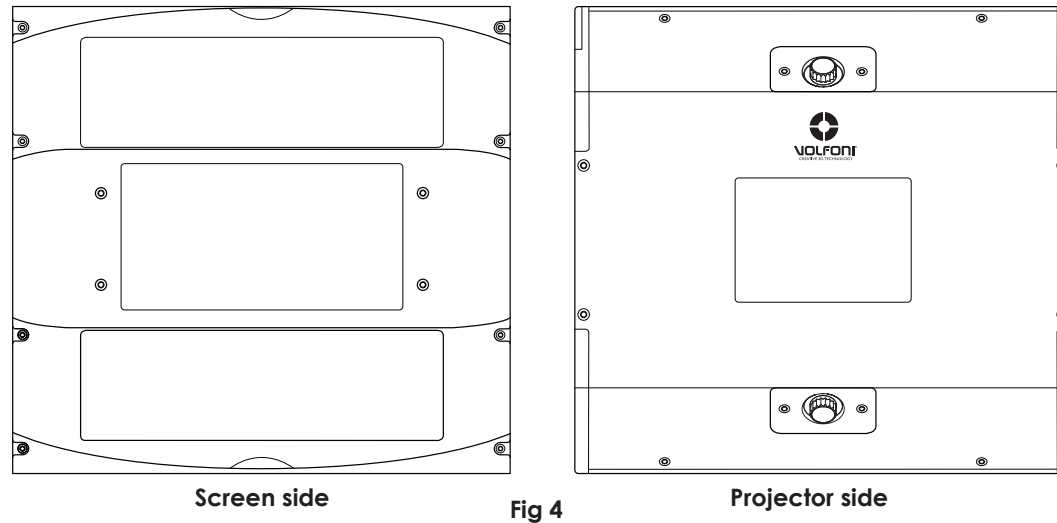

On both sides (left and right) of the SmartCrystal™ Diamond Box are fitting wheels for the upper and lower half images. They enable you to adjust the position of the two half images vertically and horizontally.

They are completed with two zoom wheels located on the projector side of the device. All of these six wheels are used to align/superimpose the two half images on the central image.

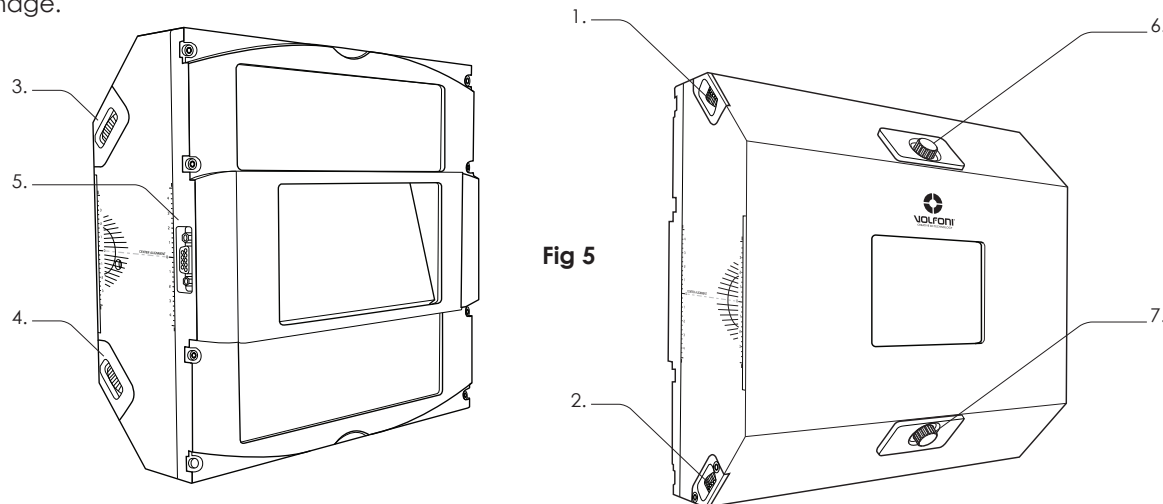

- 1- Upper half image left/right adjustment wheel
- 2- Lower half image left/right adjustment wheel
- 3- Upper half image up/down adjustment wheel
- 4- Lower half image up/down adjustment wheel
- 5- Connector of the SmartCrystal™ Diamond box (SubD-9)
- 6- Upper half image +/- zoom wheel
- 7- Lower half image +/- zoom wheel

2.2 SmartCrystal™ Diamond Controller

2.2.1 General presentation

The SmartCrystal™ Diamond Controller is the electronic unit of the system. Figure 6 shows a general view of the SmartCrystal™ Diamond Controller.

Fig 6

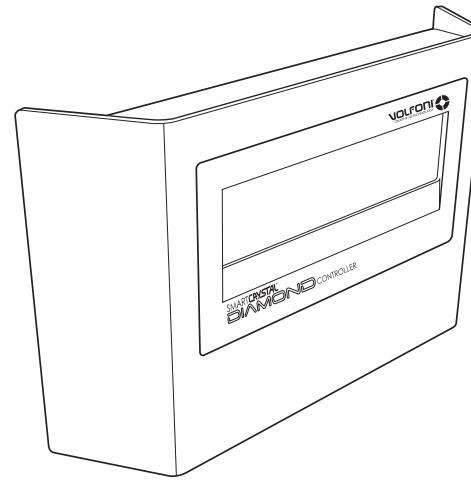

2.2.2 Detailed presentation

Fig 7

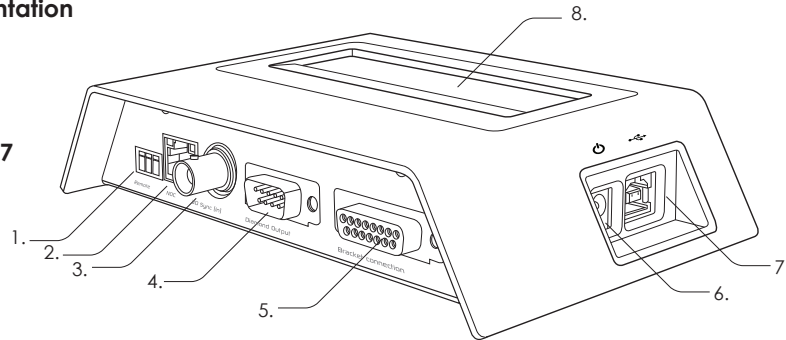

- 1- Automation – pluggable terminal block connector (3 points): It enables you to control the system automatically with 'hit or miss' electrical entries.
- 2- Network Operating Center (NOC) – RJ45 connector: It enables you to run and to interact with the system from a remote/relocated computer centre.
- 3- Sync_3D – BNC connector: Synchronization signal generated by the projector or another source.
- 4- SCD Box interface - SUBD9 connector: This interface is used to run the SCD Box.
- 5- Bracket-connector SUBD15 interface: This duplex interface is used to interact with the bracket and to run it to automate 2-D/3-D modes.
- 6- V5 feeding of the SmartCrystal™ Diamond Controller. This entry should be used with an external feeding whether the system is not fixed to an automated bracket.
- 7- Maintenance – USB connector: Entry designed for SmartCrystal™ Diamond Controller software maintenance.
- 8- Digital information area about the system state and functioning.

The following Figure is a view of the SmartCrystal™ Diamond Controller digital display.

The screen displays:

- A: The current working mode: 2-D or 3-D.
- B: The vision frequency received by the system through the SYNC_3D entry.
- C: Other information about the system: bracket state etc.

Fig 8

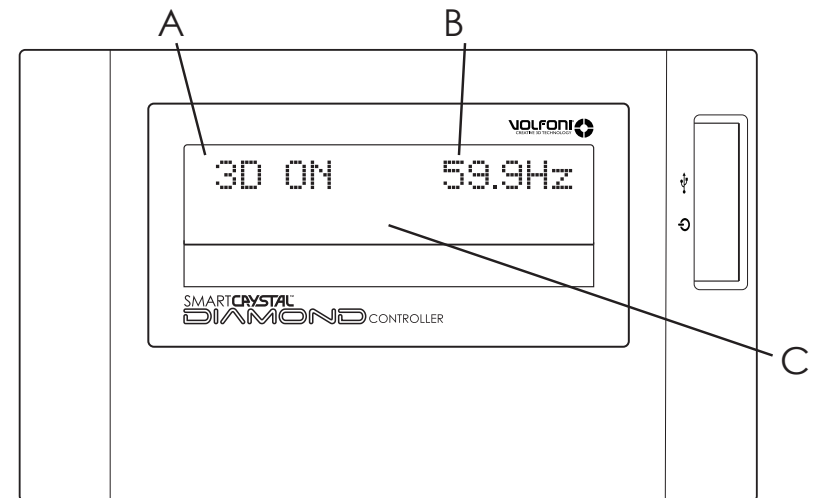

The SCD Controller can be fixed using the perforations located on the back of the box (pict. 1.3.5).
The distance between these two mounting points is 8,5 cm.

Fig 9

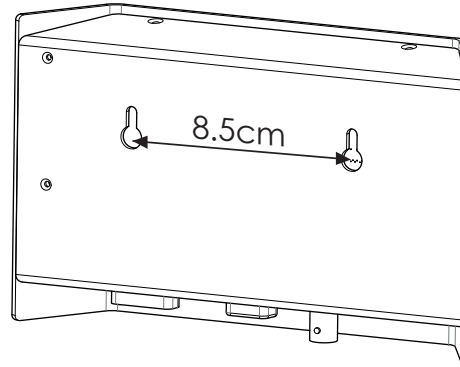

2.3 The SmartCrystal™ Diamond bracket

The SmartCrystal™ Diamond Box must be assembled with a bracket which enables you to fit its position opposite the projector with high precision: Height, angle, distance from the projector (i.e. projector lens), lateral movement for the 2-D/3-D modes.

Fig 10

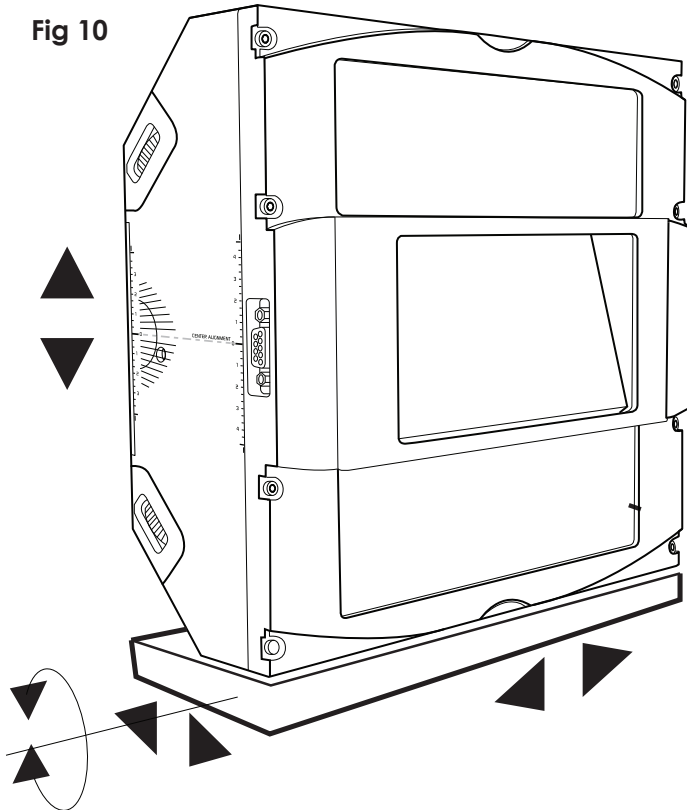

WARNING

To avoid any damage to projector lens:

- The bracket have to be correctly fixed on the table or on the wall
- The product can move along the slide in both direction without touching the lens

Volfofi provides the bracket to position the SmartCrystal™ Diamond Box properly in front of the projector lens.

For assembling instructions, please refer to the bracket user guide. It contains the possible assembly drawings depending on the various configurations.

3. Requirements and important recommendations to install the SmartCrystal™ Diamond

IT IS ABSOLUTELY ESSENTIAL TO MEET THE FOLLOWING CRITERIA TO INSTALL THE SMARTCRYSTAL™ DIAMOND BOX.

3.1 Room configuration

- Minimum size of the room window: 40cm X 40 cm

Such an outflow image of the SmartCrystal™ Diamond Box requires that the size of the room window must be at least 40cm x 40cm if the 'screen' side of the system stands at less than 10cm from this window.

The farther the device will be positioned from the room window, the larger the size of this latter should be. Do not hesitate to contact your supplier for any technical support.

- Image centering on the window

The projector has to be installed so that the image is centered to the room window, requirement all the more important if the latter is minimum-sized (40cm X 40cm).

- The projection room window should not depolarise light.

- The image size 2cm from the lens must not exceed 10 cm X 7 cm. This size corresponds to the size of the SmartCrystal™ Diamond Box inflow window.

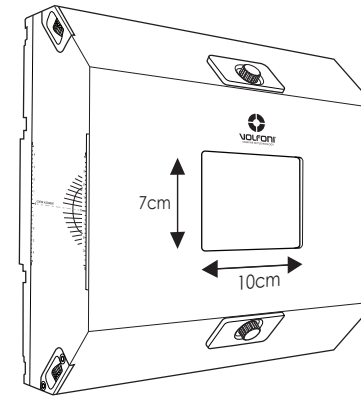

Fig 11

3.2 Film theatre configuration: 'Throw Ratio' of the cinema

Before any installation, making sure that the device is compatible with the theatre is important. The 'Throw Ratio' (TR) enables a first assessment.

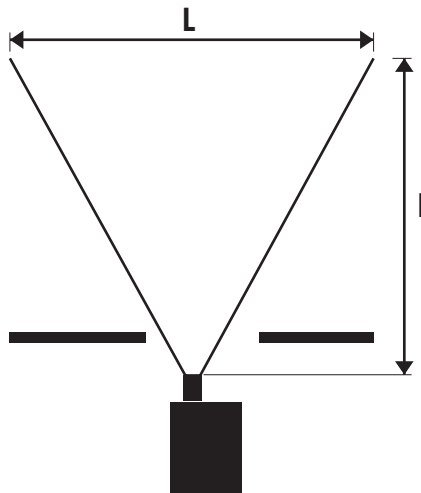

Fig 12

If the projector outflow image meets the previous requirements (*), the 'Throw Ratios' to respect are the following:

THROW RATIO	Config Flat – 1.85	Config Scope – 2.39
DLP 1.2" PROJECTOR	TR >= 1.35	TR >= 1.2
DLP 0.98" PROJECTOR	TR >= 1.30	TR >= 1.2

(*) : The SmartCrystal™ Diamond Box must be situated as close as possible to the lens, i.e. less than 2cm.

$$TR = (\text{Distance between projector and screen} \Rightarrow I) / (\text{screen width} \Rightarrow L)$$

4. SmartCrystal™ Diamond assembly

This part guides the user to:

- Position the system
- Adjust the system
- Test a 3-D projection

4.1 Loading the adjustment pattern

Before any installation please load the adjustment pattern into the server and display it on the screen. The pattern is stored in the USB key provided with the device.

4.2 Bracket installation

Please refer to the bracket user manual, provided with the bracket.

Reminder:

- The bracket must be installed following the instructions of its user manual. These instructions are extremely important and must be respected to allow an optimum and satisfying SCD Box adjustment.

- The upper plate of the bracket must be pre-positioned 13cm far from the beam centre, so as in the figure below.

4.3 Installation of the SmartCrystal™Diamond Box on the bracket

The authorized technician so far:

- Has made sure that every other equipment meets the safety and installation standards (projector, server etc).
- Has assembled the SmartCrystal™ Diamond bracket in a secured way, according to the projector configuration and other prerequisites (please refer to the bracket user manual).

4.3.1 Assembly of the SmartCrystal™ Diamond box on the bracket

The purpose of this step is to assemble the SCD Box with the bracket and to make sure there is no risk of contact with the projector and its lens.

- Position the carriage as far as possible from the projector lens in order to avoid any risk of contact with this latter during the assembly of the SmartCrystal™ Diamond Box on the carriage.

- Assemble the SmartCrystal™ Diamond with the bracket carriage.

- After positioning the SmartCrystal™ Diamond Box, fix it on the carriage using 4 screws.

The screws and the wrench are provided with the system (see packing list).

- As the SmartCrystal™ Diamond Box is properly fixed on the carriage, make the carriage slide and check the absence of contact with the projector and its lens. In case of contact, fit the bracket adjustment to eliminate any risk of contact.

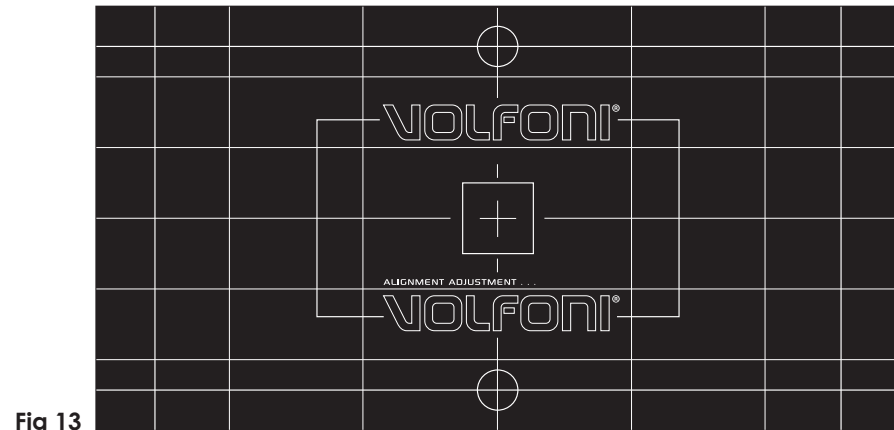

Fig 13

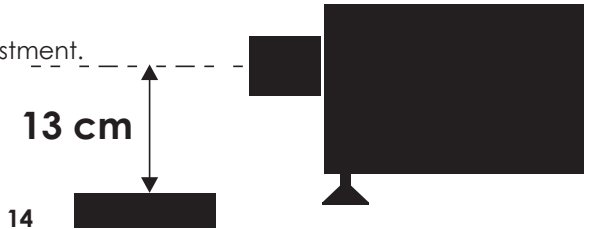

Fig 14

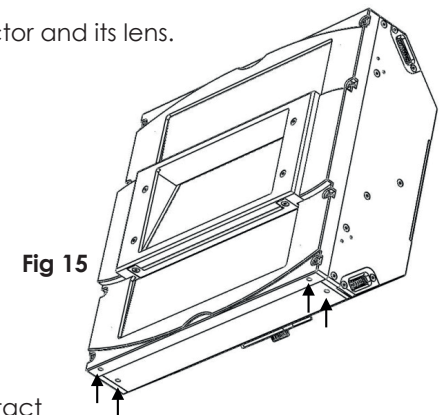

Fig 15

4.3.2 Adjustment of the SmartCrystal™ Diamond Box position

The purpose of this step is to position the SCD Box properly towards the light coming from the projector.

- Make the carriage slide so that the beam of light from the projector lights up the side of the SmartCrystal™ Diamond Box (see pict. 4.3.2.1 which shows a view from above).

This process can be carried out using the left side or the right side of the SmartCrystal™ Diamond box.

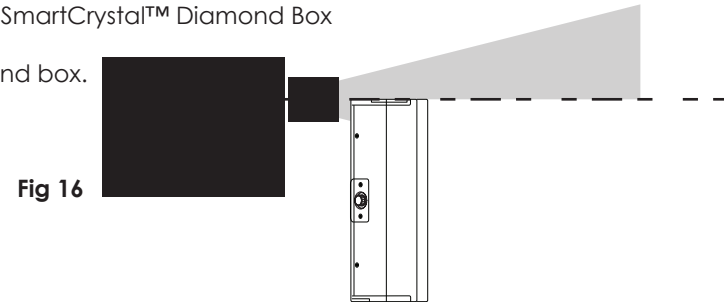

- Adjust the position (height, angle) of the SmartCrystal™ Diamond Box in relation to the beam light from the projector using the graduations on the sides of the SmartCrystal™ Diamond Box.

To fit this, use the carriage adjustment units of the bracket (see bracket user manual)

The ideal position is when the beam light is centred at the inflow and at the outflow of the SCD Box, as mentioned by the figures below.

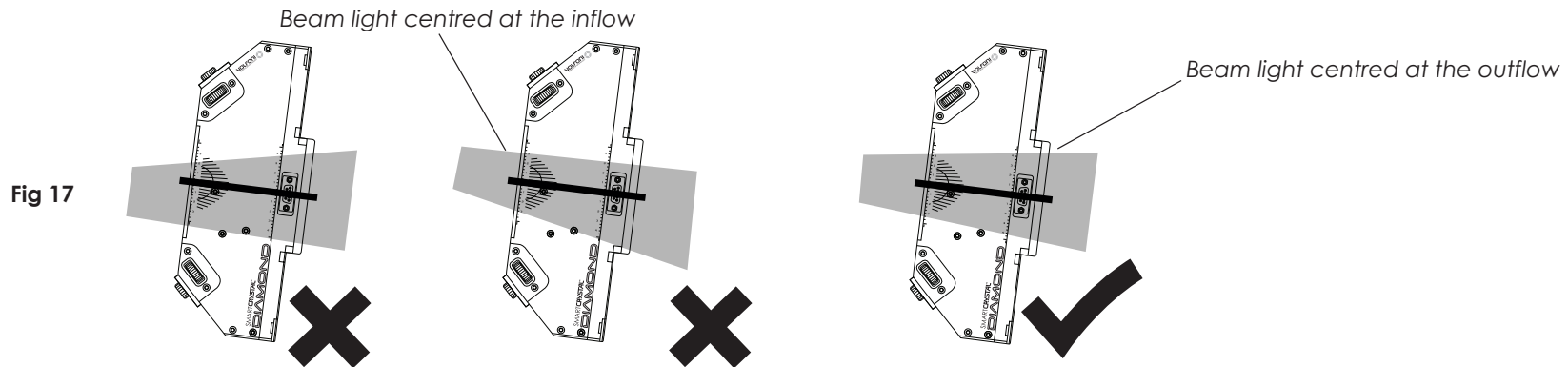

- This step might alter slightly the position of the SCD Box in relation to the projector lens. Check again (removal/bringing close) by making the carriage slide:
 - There must be no contact between the device and the projector (lens included).
 - The SmartCrystal™ Diamond Box must be as close as possible to the projector lens without touching it, i.e. less than 2cm.

Fit in the bracket again if necessary.

If you alter one of the adjustments (position or orientation), you systematically need to carry out all the checks and repeat the process as many times as necessary. If you have respected the procedure, one iteration should be enough.

- As the position and the orientation are satisfying, the SCD Box is installed.

4.3.3 2-D/3-D position stops

The stops enable you to define accurately and permanently the positions of the SCD Box for the 2-D and 3-D projection modes

• Adjustment of the 3-D position

In 3-D mode, the SCD Box must be positioned so that the projector beam outflow is horizontally centred on the central window of the projector front and also on the outflow window (screen side).

- Fixing the 3-D position :

- If possible, look at the SmartCrystal™ Diamond Box screen side and make sure that the central image is properly centered like figure 18.

- At this moment, do not worry about the position of the upper and lower half images.

- Look at the SmartCrystal™ Diamond Box inflow window and make sure that the central image is properly centered like figure 19.

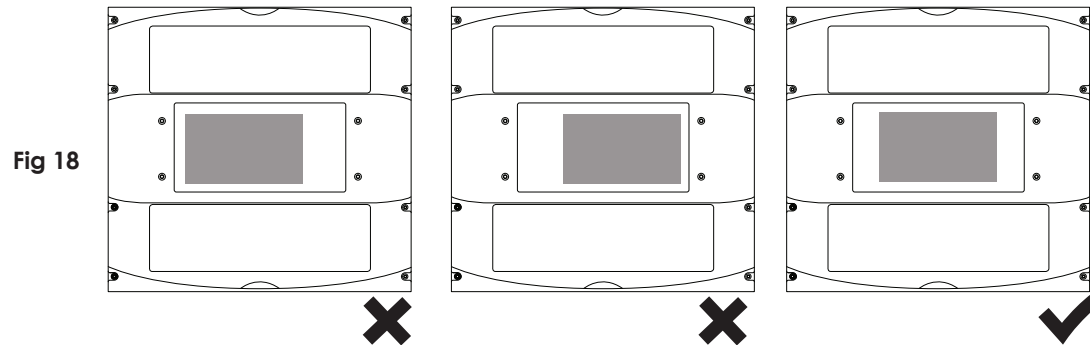

- As the SmartCrystal™ Diamond Box is properly positioned, lock the bracket stop in 3-D position (see bracket user manual).

- It is then possible to make the carriage slide and to come back easily and accurately to this position.

• Adjustment of the 2-D position

In 2-D mode, the position of the SCD Box should not interfere with the projector beam.

- Make the bracket carriage slide until the SCD Box is out of the beam light.

Do not hesitate to take a margin of room in order to avoid any subsequent problem.

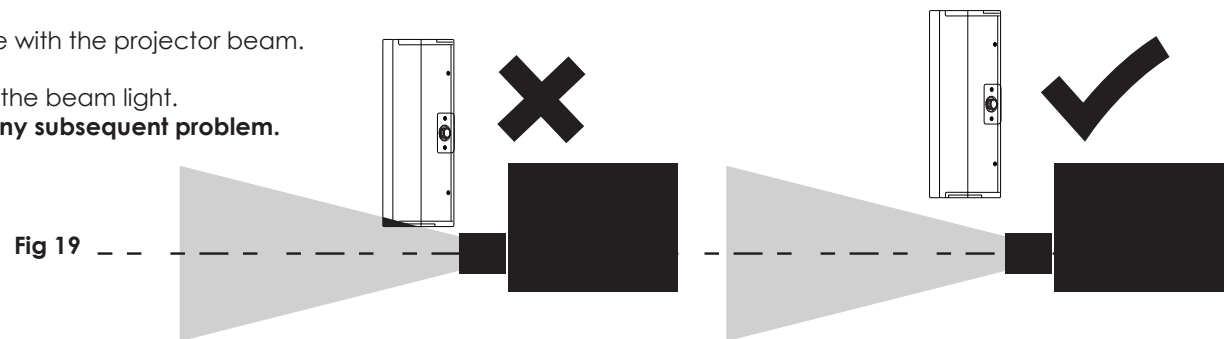

- As the SmartCrystal™ Diamond Box is properly positioned, lock the bracket stop in 2-D position (see bracket user manual).

The installation and the positioning of the SmartCrystal™ Diamond Box are now completed. Re-position the SCD Box in front of the projector lens (3-D position) for the next operation (image adjustment).

4.4 Image adjustment

Now that the SCD Box is properly positioned, we can carry out the image adjustment. The principle consists in aligning every half image (upper and lower) with the central image

The fitting wheels are located on each side so as on the projector side of the SmartCrystal™ Diamond Box.

- On one side of the SmartCrystal™ Diamond Box, you will find the up/down adjustment wheels of the upper half image (at the top) so as of the lower half image (at the bottom). They can be spotted with the 'left/right' inscription.
- On the other side of the SmartCrystal™ Diamond Box, you will find the right/left adjustment wheels of the upper half image (at the top) and of the lower half image (at the bottom). They can be spotted with the 'left/right' inscription.
- On the front projector side of the SmartCrystal™ Diamond Box, you will find the zoom in/out wheel for the upper half image (at the top) and the zoom in/out wheel for the lower half image (at the bottom). They can be spotted with the 'adjust' inscription.

Before starting the image adjustment, display the Volfoni adjustment pattern on the screen. The observed screen image shows line splittings and different gaps between the upper and the lower parts of the image.

4.4.1 Fitting the upper half image

The purpose of this step is to superimpose all the information of the upper half of the image proceeding as following:

First of all you need to make sure that the adjustable wheel is unlocked.

To do so, you have to maintain in position the top part of the adjustable wheel (1)

then unscrew (rotate clockwise) the bottom part of the adjustable wheel (2)

until feeling the stop. During this step you must not force.

This locking system is working on the principle nut/locknut.

The system is now ready to be set.

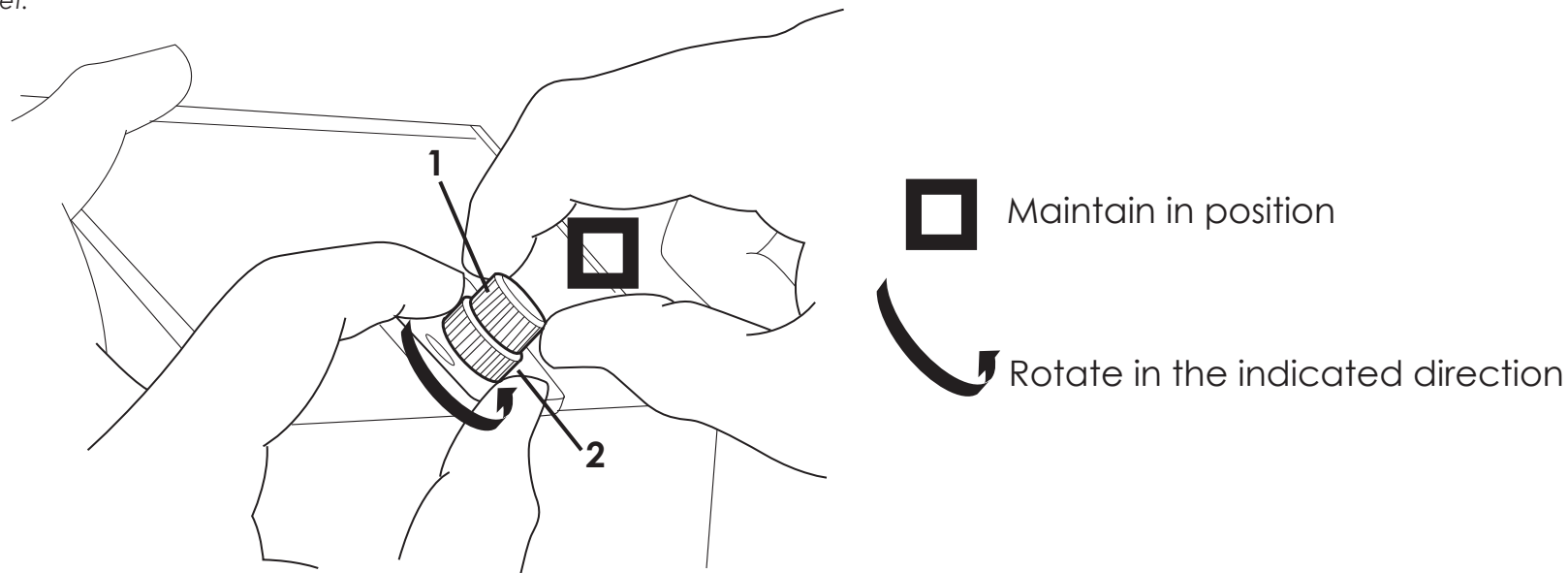

- **Left/right fitting observing the VERTICAL lines**

- o Align/superimpose the vertical lines at the centre of the upper image using the left/right wheel located at the top of the device (n°1 wheel of the figure 5).

- o When the aligning is correct at the centre, the vertical lines on the image sides are not systematically superimposed. Check that gaps between the lines are identical on the left and the right of the image (see image below).

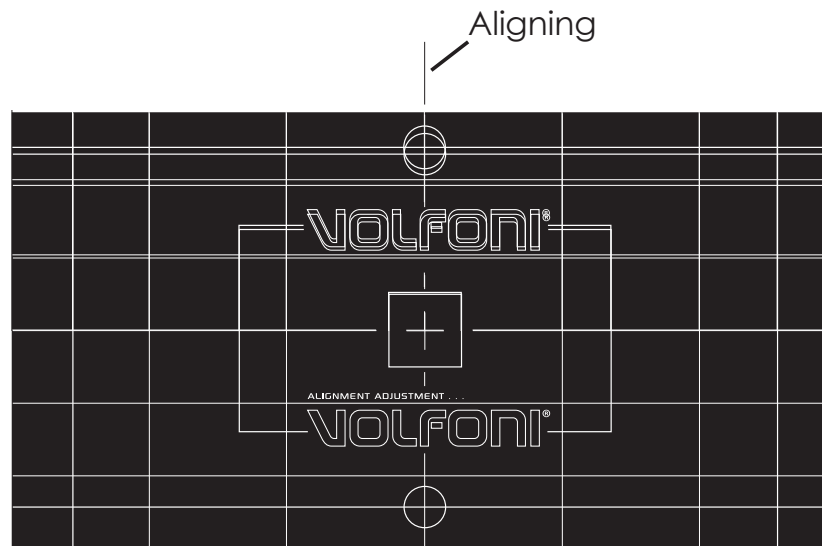
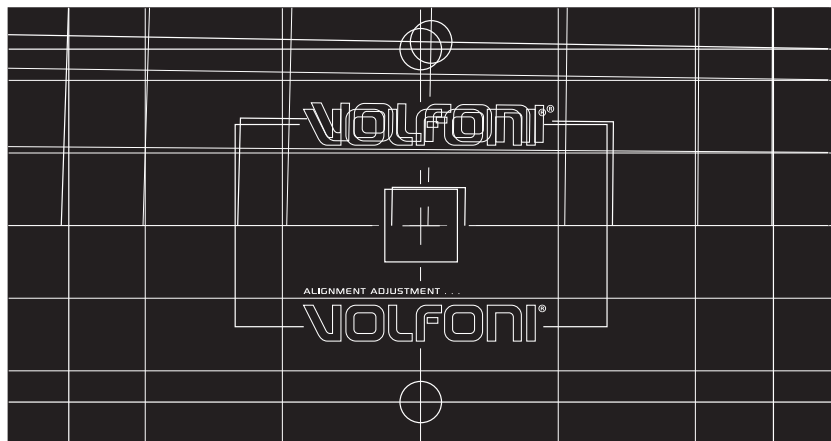

OR

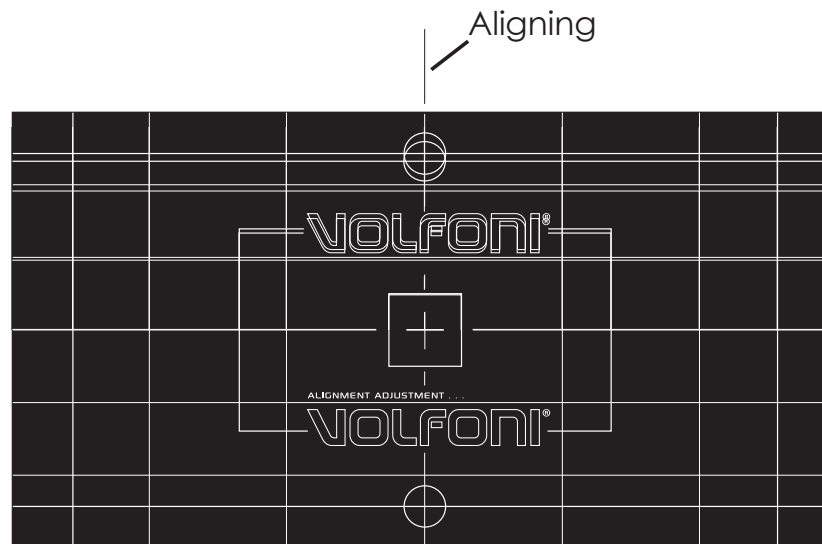
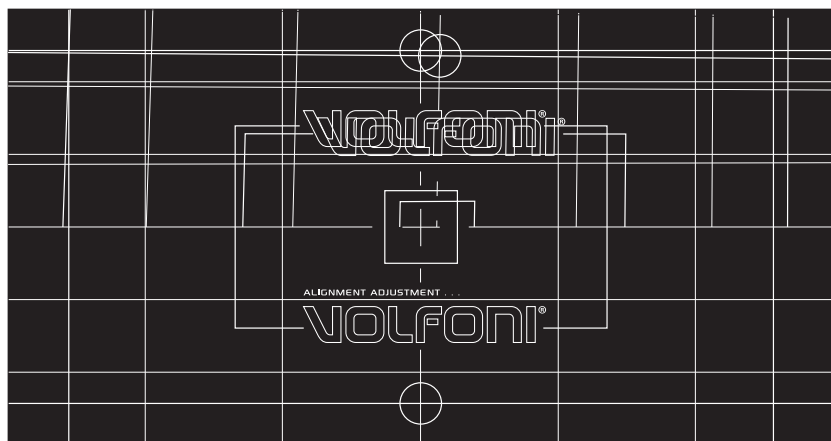

- **Up/down fitting observing the HORIZONTAL lines**

- Align/superimpose the horizontal line(s) of the upper image using the 'up/down' wheel located at the top of the device (n°3 wheel of the figure 5). Focus mainly on the centre of the image (the horizontal lines at the top of the image are probably still irregular, which is not disturbing at the moment).

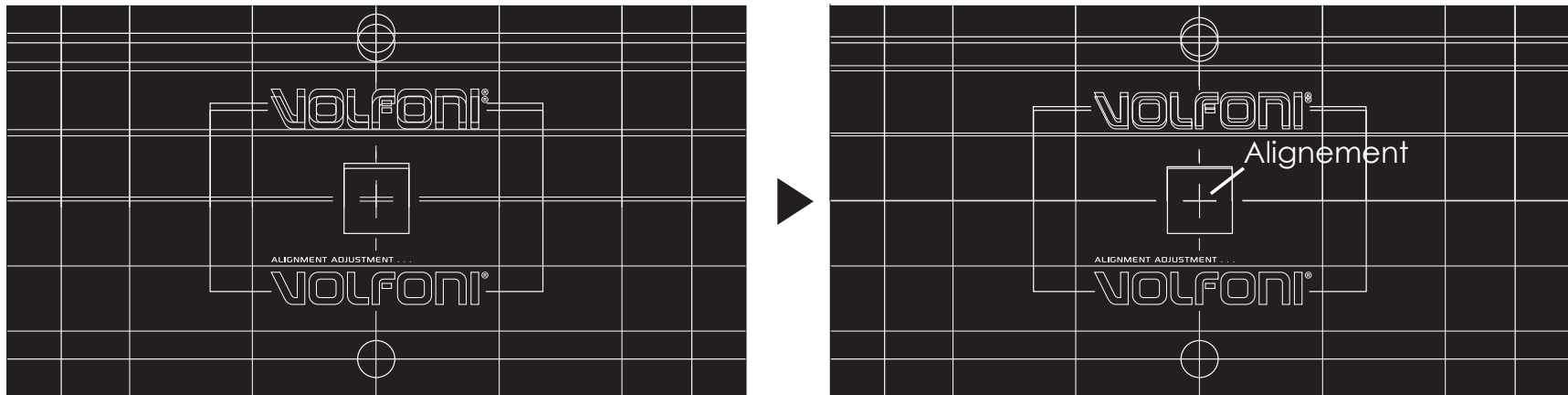

- **'Scale/zoom' size fitting**

- Using the upper central wheel (n°6 wheel of the figure 5), fit the size of the upper half image superimposing all the information (lines, circles, text).

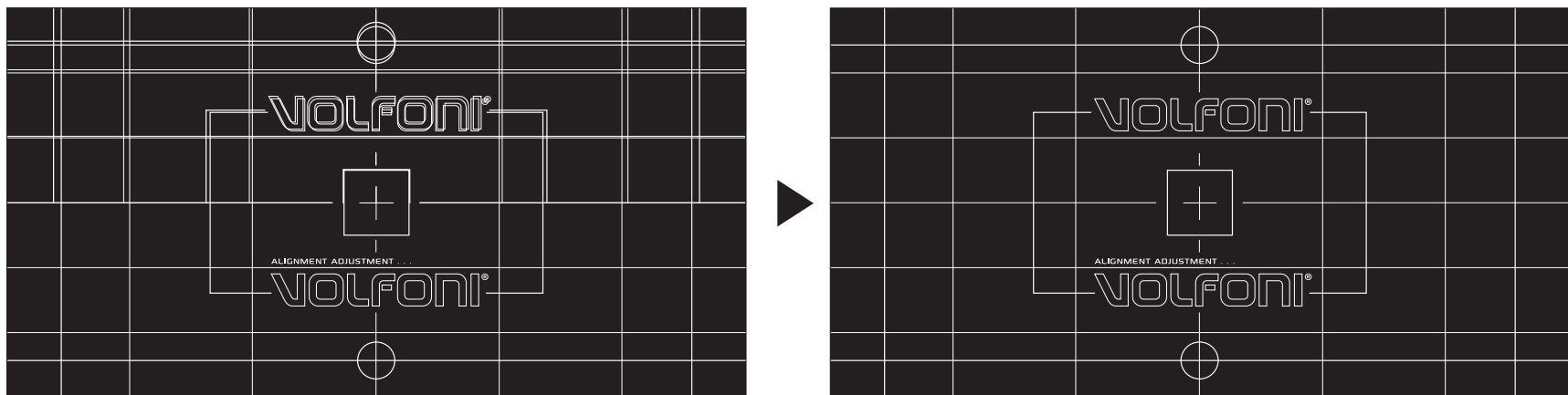

• **Final fitting**

At the end of the previous adjustment, the superimposition might not be optimum.

The three previous steps need to be repeated, proceeding to a finer fitting until you get a satisfying result. The adjustment is satisfying when there is no image splitting on the upper half image anymore.

Now as the adjustment of the top image is completed you have to lock it.

To do so, you have to maintain in position the top part of the adjustable wheel (1) then screw (rotate counterclockwise) the bottom part of the adjustable wheel (2) until the stop. The locking can have a slight impact on the 'Scale/zoom' size fitting. In this case you have to unlock the adjustable wheel (do the contrary of the previous step) then start over until finding the good balance.

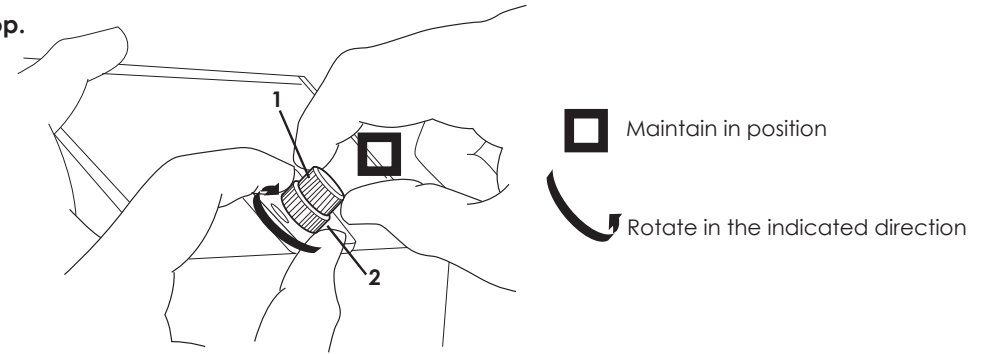

The adjustment of the upper half image is completed.

4.4.2 Fitting the lower half image

The purpose of this step is to superimpose all the information of the lower half of the image proceeding as following:

First of all you need to make sure that the adjustable wheel is unlocked. To do so, you have to maintain in position the top part of the adjustable wheel (1) then unscrew (rotate counterclockwise) the bottom part of the adjustable wheel (2) until feeling the stop. During this step you must not force. This locking system is working on the principle nut/locknut. The system is now ready to be set.

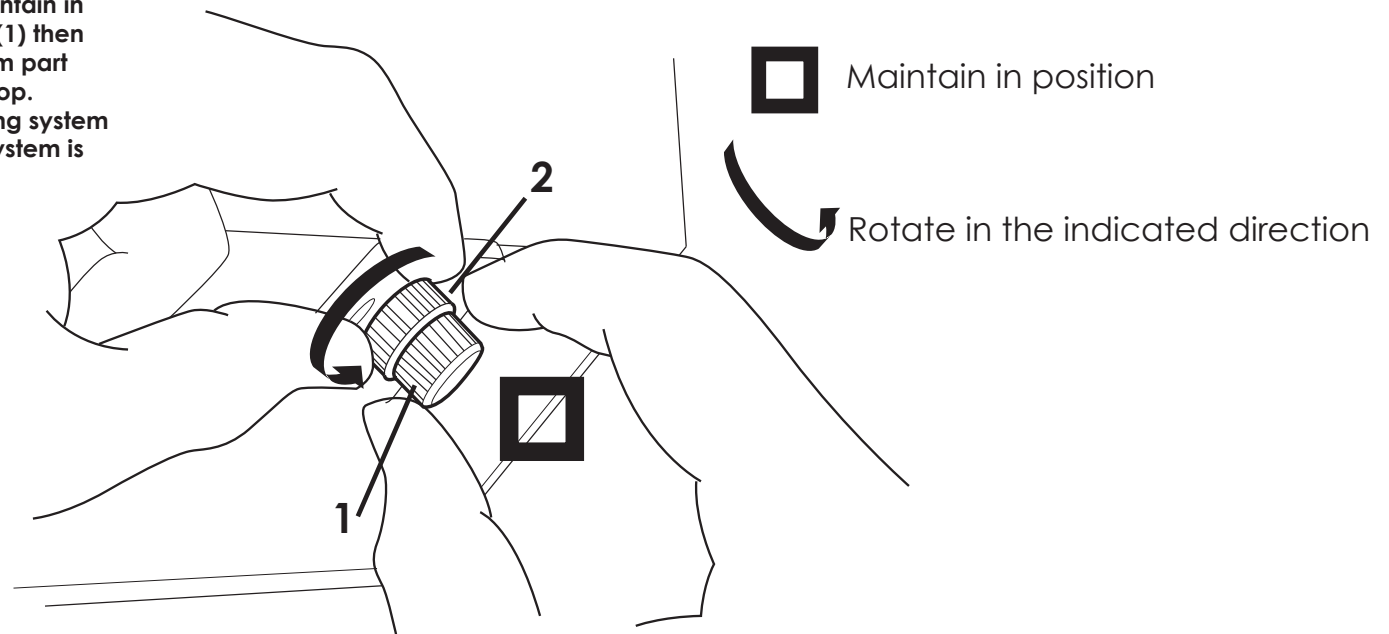

- **Left/right fitting observing the VERTICAL lines**

- o Align/superimpose the vertical lines at the centre of the lower image using the left/right wheel located at the bottom of the device (n°2 wheel of the image 5).

- o As the aligning is correct at the centre, the vertical lines on the image sides are not systematically superimposed. Check however that the gaps between the lines are identical on the left and the right of the image (see figure below).

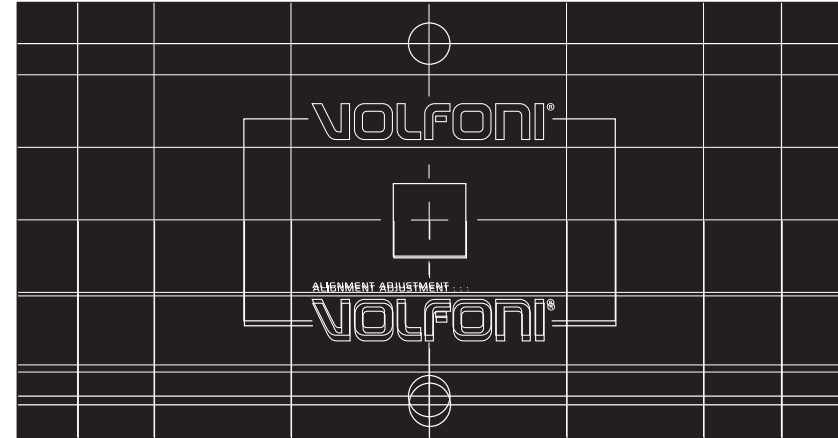
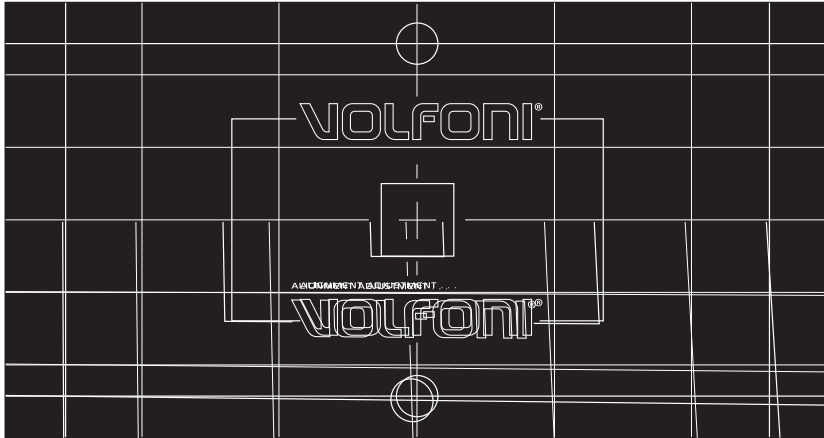

ou

↙ Alignement

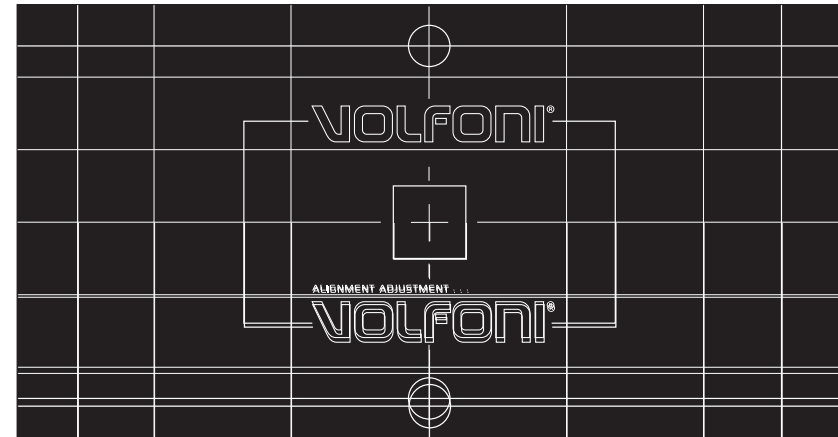
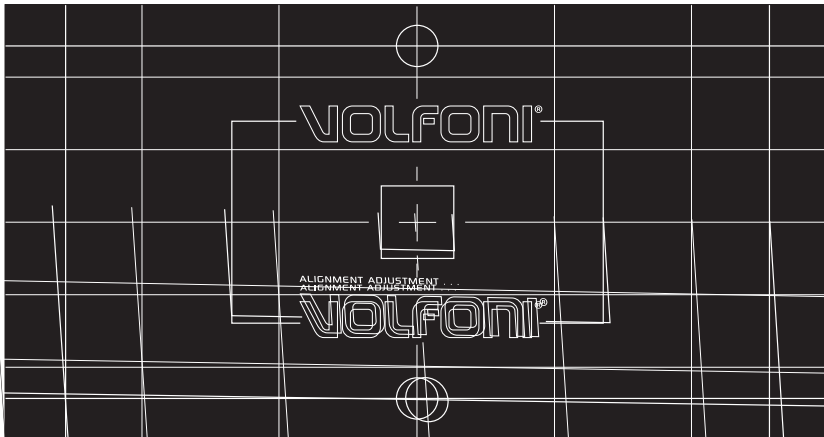

↙ Alignement

- **Up/down fitting observing the HORIZONTAL lines**

Align/superimpose the horizontal line(s) of the lower image using the 'up/down' wheel located at the bottom of the device (n°4 wheel of the figure 5). Focus mainly on the center of the image (the horizontal lines at the top of the image are likely still irregular, which is not disturbing at the moment).

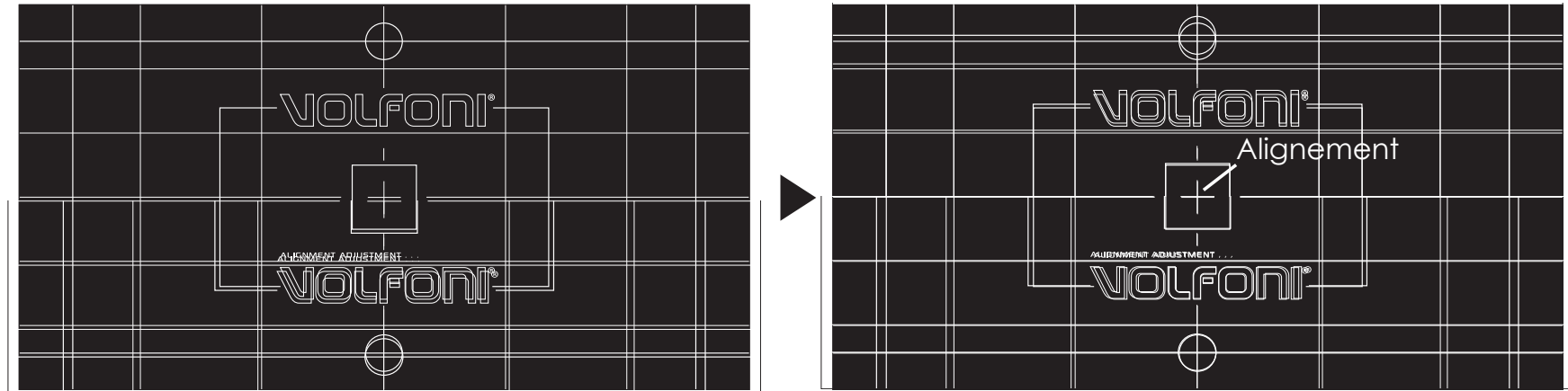

- **'Scale/zoom' size fitting**

Using the central wheel (n°7 wheel of the figure 5), fit the size of the lower half image by superimposing all the information (lines, circles, text).

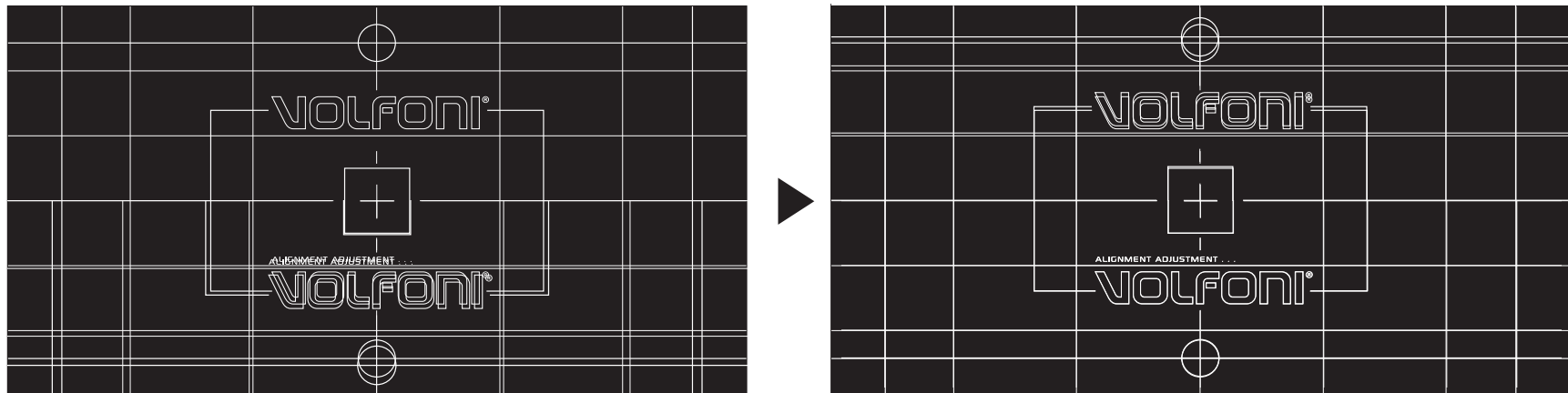

- **Final fitting**

At the end of the previous adjustment, the superimposition might not be optimum.

The three previous steps need to be repeated, proceeding to a finer fitting until you get a satisfying result. The adjustment is satisfying when there is no splitting information on the lower half image.

- **Final locking**

Now as the adjustment of the bottom image is completed you have to lock it.

To do so, you have to maintain in position the top part of the adjustable wheel (1) then screw (rotate clockwise) the bottom part of the adjustable wheel (2) until the stop.

The locking can have a slight impact on the 'Scale/zoom' size fitting.

In this case you have to unlock the adjustable wheel (do the opposite of the previous step) then start over until finding the good balance.

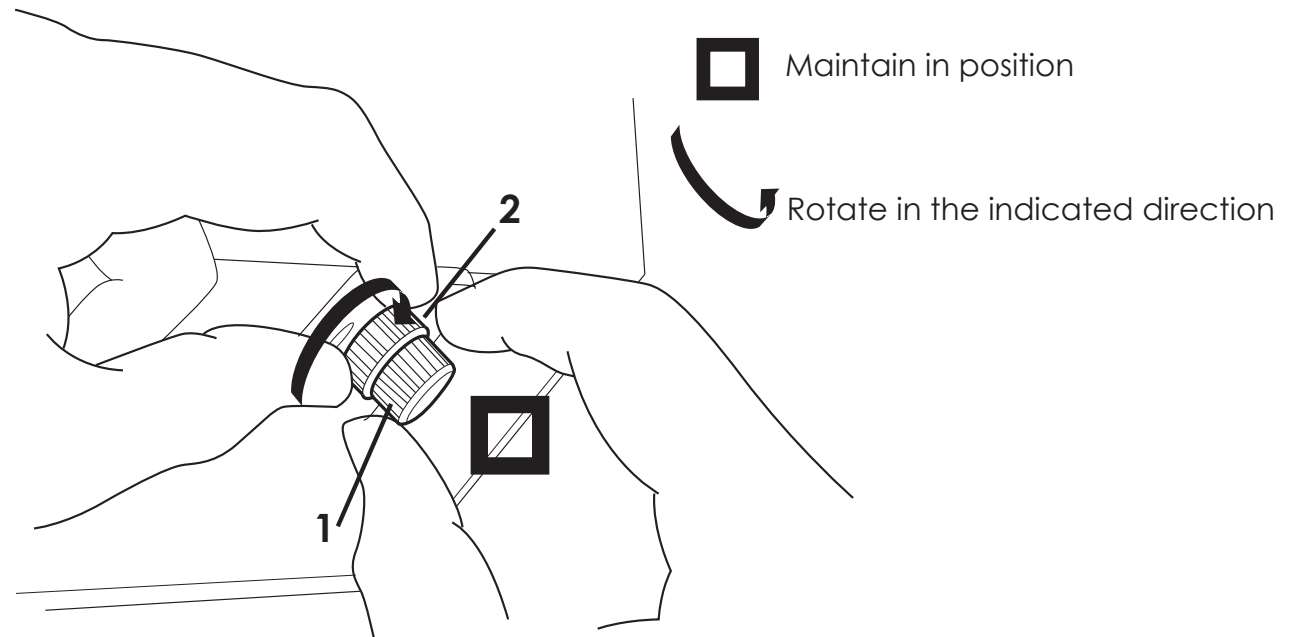

THE UPPER HALF IMAGE ADJUSTMENT IS COMPLETED.

THE IMAGE ADJUSTMENT IS COMPLETED. THE ELECTRICAL CONNECTIONS REMAIN TO BE MADE SO THAT YOU HAVE A FUNCTIONAL SYSTEM.

4.5 SmartCrystal™ Diamond Controller plug-in

4.5.1 Case of an installation with a manual bracket

For this installation configuration, you need to use the (provided) external feeding to make the system work.

The connection of the system is such as the following figure:

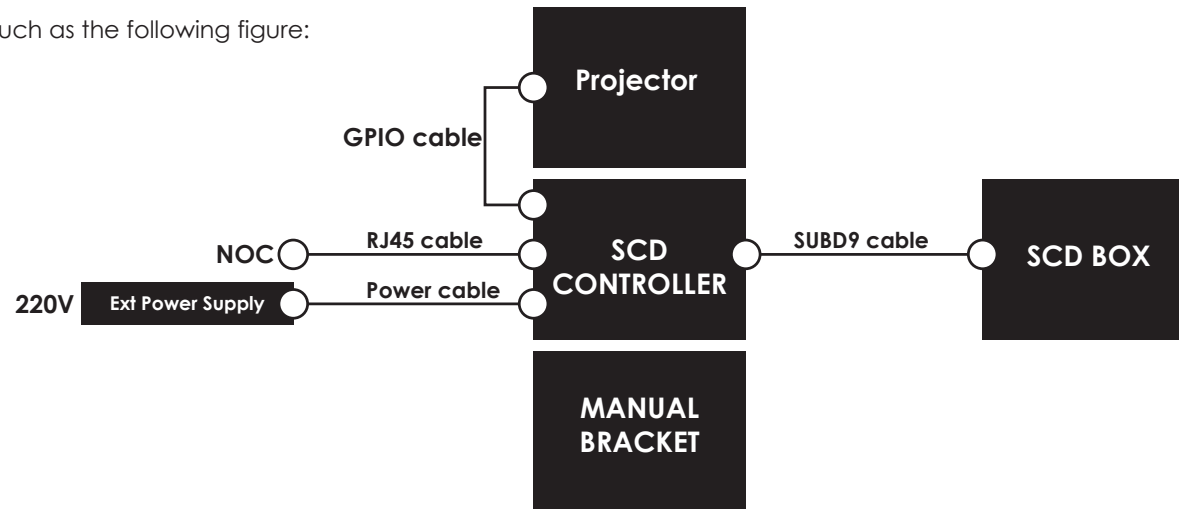

- Connect the SubD9 cable with the SCD Box and the SCD Controller.
- Connect the synchronization cable (GPIO37 / BNC or GPIO15 / BNC) with the projector and the SCD Controller.
- Connect the feeding cable and the external feeding with the SCD Controller.
- The system is working:

o If the projector is in 3-D mode, the SCD Controller displays:



- '3D ON'
- The value of the synchronization frequency given by the projector

o If the projector is in 2-D mode, the SCD Controller displays:

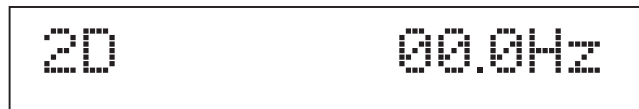

- '2D'

4.5.2 Case of an installation with a motorized bracket

In this installation configuration, the system is fed by the bracket.

The use of the (provided) external feeding is then no longer necessary to make the system work.

The connection of the system is such as the following figure:

- Connect the SUBD9 cable with the SCD Box and the SCD Controller.
- Connect the synchronization cable (GPIO37 / BNC or GPIO15 / BNC) with the projector and the SCD Controller.
- Connect the SUBD15 cable with the SCD Box and the bracket.
- Connect the bracket feeding cable.

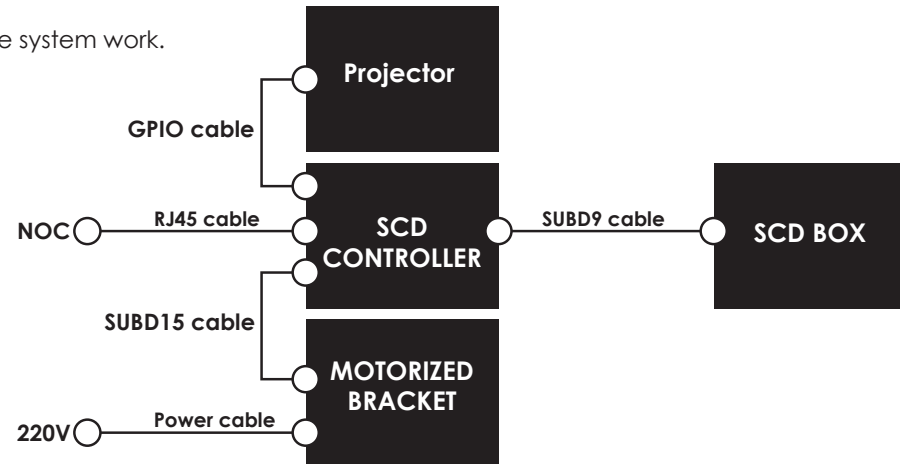

- The system is working:

- o If the projector is in 3-D mode, the SCD Controller displays:

- '3D ON'

- The value of the synchronization frequency given by the projector

```
3D ON    96.0Hz
```

- o If the projector is in 2-D mode, the SCD Controller displays :

- '2D'

```
2D      00.0Hz
```

- The SCD Controller also displays the status of the SCD Box bracket:

```
BRACKET OK
```

The bracket is properly fitted (2-D or 3-D).

```
BRACKET UNREADY
```

The bracket is not properly fitted.
This message is displayed when the bracket is in motion towards the right position (2-D or 3-D)

```
BRACKET ERROR
```

Error message displayed when:
i. the bracket is wrongly connected with the SCD Controller, or
ii. a problem (blocking) has occurred during the bracket movement.

4.6 3-D functioning test

The DLP projectors can be configured, i.e. many parameters must be adjusted so that a screening works properly. Before displaying a pattern or a 3-D movie with the SmartCrystal™ Diamond, it is important to make the following adjustments:

- DarkTime adjustment
 - o The 'Dark Time' must be adjusted between 800µs and 1200µs. Volfoni recommends 1000µs.
 - o In some configurations, the optimum value may be out of this range.

If you notice an excessive 'ghosting' effect, test other values for the DarkTime, increasing it in 200µs stages until 2000µs.

Do not hesitate to contact your technical support.

- 'Delay' must be adjusted at 0 µs

Once these parameters are captured in the projector, a pattern or a 3-D movie can be started to check if the system is properly working with passive glasses.

5. Additional anti-reflection filter

5.1 Context

An optional additional filter is in the packaging. In some installations, some 'room' windows may not be processed with an anti-glare layer or it might be insufficient/inadequate. In this case, you might notice undesirable reflections on the screen.

Volfofi has developed this filter in order to compensate for this situation to the detriment of a loss of light power. We recommend using this filter as a last resort only and advise instead to change the window angle in order to deflect the reflection or to change it.

5.2 filter assembly

It is absolutely essential to carry out this process after the SmartCrystal™ Diamond Box has been dismantled from the bracket, and to make all necessary arrangements to protect the equipment before operating. Any operation on this installed unit is delicate and may probably damage it.

Proceed as following to assemble the filter:

- Before any operation, it is necessary to have a clean and secured work environment for the SmartCrystal™ Diamond Box so as its filter.
- Dismantle the SmartCrystal™ Diamond Box from its bracket.
- Dismantle the mask located under the central window of the SmartCrystal™ Diamond Box (screen side), in purple in figure 21. The two screws located on each side must be unscrewed.

As you have dismantled this component, we invite you to keep it carefully.

- Insert the filter making it slide like the following figure.

Warning: never force and never leave the device without mask or filter.

- Fix the filter with the two screws initially used to fix the mask.

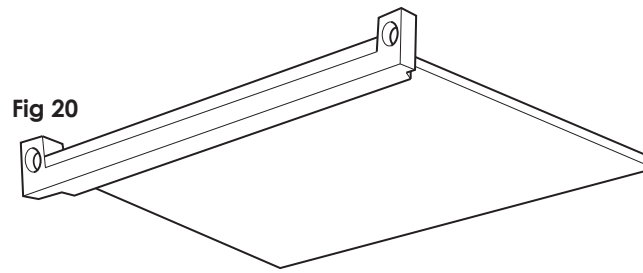

Fig 20

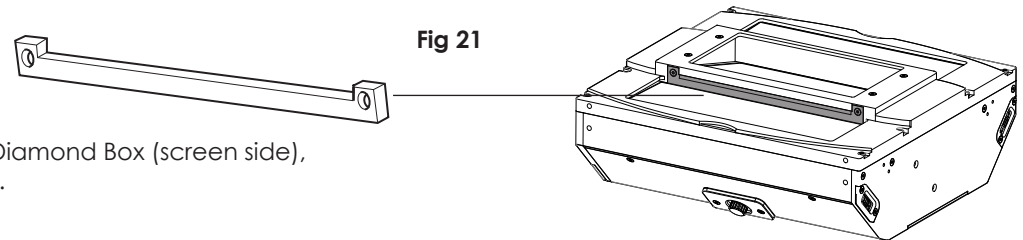

Fig 21

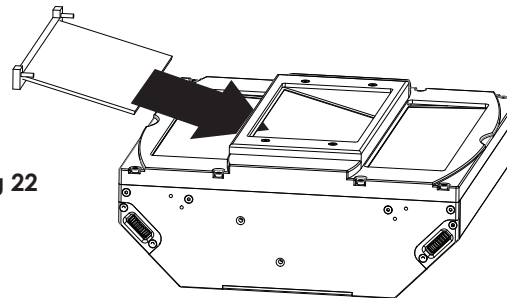

Fig 22

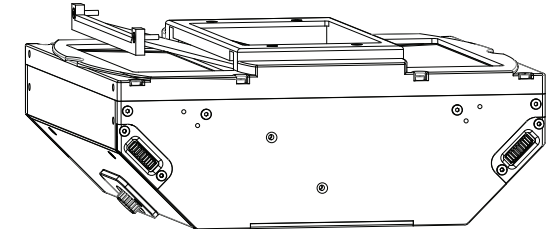

Fig 23

- The operation is now completed. Reposition the device and check that the reflections have disappeared.
- This operation may have disturbed the installation and the system adjustments. You need to check that the image superimposition is still satisfying. Otherwise, carry out all the adjustment steps again.

6. Software interface

6.1 Introduction

The system is run by the SCD Controller.

Several operations can be carried out such as:

- Update of the software version of the SCD system
- Change of the default working settings (3-D mode automatic detection for instance)
- Diagnosis (unavailable)

6.2 SCD software version

The system is run by the SCD Controller. By default, the system is delivered with the newest software version at the moment the product was manufactured. A new software version might be available when you receive/install your system.

On receipt of equipment, Volfoni recommends to carry out the following operations to ensure you have the latest software version:

- Visit the Volfoni website: www.volfoni.com
- Select the 'SERVICES/SUPPORT' menu
- Select 'DOWNLOAD'
- Download, install and launch the 'VOLFONI LOADER' program
- Connect your computer with the SmartCrystal™ Diamond Controller using the USB-A /USB-B cable (cable provided by Volfoni)
- Feed the SmartCrystal™ Diamond Controller with the external feeding (provided by Volfoni)
- Check that the program recognizes the SmartCrystal™ Diamond Controller
- As the SmartCrystal™ Diamond Controller is connected, press 'CHECK FOR UPDATE'
 - If your system uses the latest version, the program will indicate that your system is up to date.
 - If the version is not the latest, accept and launch the new version loading.

During this process, warning :

- **Do not disconnect the SCD Controller from your computer**
- **Do not unplug the SCD Controller feeding**

6.3 Functioning modes, settings, other functions

The SCD Controller has other functions:

- Activation/inhibition of the working mode
- Settings change
- Remote running (Network Operating Center)
- Functioning data recording

For further information, refer to the XXXX document (Document in progress, please contact Volfoni support), which contains all the information.

For any question, do not hesitate to contact your support.

7.Troubleshooting

PROBLEM	POSSIBLE REASONS	SOLUTIONS
Hazy image, poor contrast	<ul style="list-style-type: none"> • The lens focus is wrong • The image aligning is bad • The protective films on the front and back sides have not been removed • Presence of fingerprints or dirt on the lens and/or on the SCD Box inflow and outflow windows 	<ul style="list-style-type: none"> • Fit the lens focus • Check if the protective films have been removed • Remove the protective films and clean the inflow and outflow SCD Box windows using the provided wipes • Adjust the SCD Box aligning again using the pattern
No 3-D effect	<ul style="list-style-type: none"> • Problem on the silvered screen • Projector settings are not right • The SCD Box is not connected with the SCD Controller • The SCD Controller is not plugged in • The projection window depolarizes light 	<ul style="list-style-type: none"> • Check if the screen is silvered • Check if the 'DarkTime' and 'Delay' values are right • Check the SCD Controller connections. In 3-D mode, the SCD Controller should display '3D ON' and the frequency. • Carry out a checking by removing the room window to ensure the latter do not influence polarization
Too dark image	<ul style="list-style-type: none"> • The power of the projector lamp is too low • The lamp settings are badly adjusted 	<ul style="list-style-type: none"> • Change the lamp settings
The image seems to be in 3D but the rendering is uncomfortable	<ul style="list-style-type: none"> • The right/left live wire is reversed on the projector 	<ul style="list-style-type: none"> • Change the right/left live wire (switch from 'TRUE' to 'INVERTED' or conversely) on the projector
Flickering image	<ul style="list-style-type: none"> • The SmartCrystal™ Diamond settings are faulty • The content is not 3-D • The image frequency given by the projector is not right 	<ul style="list-style-type: none"> • Check the SmartCrystal™ Diamond settings • Check if the content is in 3D • Try to check the image frequency given by the projector (see SCD Controller display)

**IF YOU DO NOT NOTICE ANY IMPROVEMENT FURTHER TO THE SUGGESTED SOLUTIONS,
PLEASE CONTACT YOUR SUPPORT.**

8.Important safety recommendations

Protect all parts of the 3D system from direct sunlight, heat or water.

- Extreme conditions may alter the product's performance.
- Do not modify the electrical or mechanical components of your 3D system.
- Do not apply force to the window of the polarization modulator.
- Do not touch the polarization window.
- Avoid vibrations and shock.
- Use a clean soft cloth when cleaning the polarization modulator to avoid scratching.
- Always transport the SmartCrystal™ Diamond system in its original packaging to avoid scratching the LCDs or the frame.
- In case of damage to the SmartCrystal™ Diamond where the skin is exposed to liquid crystal material, we recommend that you immediately wash the area with soap and water.
- In case of eye exposure to liquid crystal material, please seek medical advice immediately.
- Please note that passive 3D glasses must not be used as sunglasses.

9.Warranty

The SmartCrystal™ Diamond is protected under warranty to the original purchaser for three (3) years according to local legislation.

Equipment (modules and cables) should be returned in their original packaging along with the original proof of purchase. Equipment that is broken or scratched is not covered.

Volfoni does not guarantee uninterrupted or error-free operation of the product.

10. Further information

NOTICE:

The Volfoni Group reserves the right to make changes in the hardware, packaging or other documentation without prior written notice. SmartCrystal™ Diamond is a trademark of the Volfoni Group. All trademarks are the property of their respective companies.

www.volfoni.com

11.Regulatory standards



European Union - Disposal information

This symbol means that according to local laws and regulations your product should be disposed of separately from household waste. When this product reaches the end of its life, take it to a collection point designated by local authorities. Some collection points accept product for free.

The separate collection and recycling of your product at the time of disposal will help conserve natural resources and ensure that it is recycled in a manner that protects human health and the environment.

This Class B digital apparatus complies with Canadian ICES-003.